

# Dual-Band Vertical

For the 160 and 1750 meter bands.

by David F. Curry WD4PLI

Using a TV push-up mast, you can get surprising ground wave radiation from small vertical antennas (30 to 50 feet high) for the 1750 and 160 meter bands. Good antenna performance is critical; the antenna must be resonant with your operating frequency for transmission, and have a good ground system.

FCC regulations state a maximum-50 foot limit in the 160 to 190 kHz bands for both the feedline and antenna. Even with strict limits such as these, transmission and reception of ground wave signals from several hundred miles away are possible at low power levels of only 1 watt.

Many amateur operators would like to try this low band, but they can't find a good design for an antenna. A 160 meter antenna could easily be matched to work the 1750 meter band, but its dimensions might exceed the legal limits. In this article, I offer a good compromise, opening opportunities for someone with space restrictions.

## Antenna Description

The basic antenna assembly is in three parts: the top hat and 160 meter loading coil, the push-up mast upper and lower section, and the loading/relay system for antenna matching.

The capacity hat is the key to good radiation resistance and low angle radiation for 160 meters, and greatly improves the efficiency on 1750 meters. The size shown in the picture is 10 feet in diameter, with a wire ring around the perimeter. The wire ring further increases capacitance, adding to overall efficiency.

The telescopic portion of the antenna is a galvanized steel push-up mast you can buy at almost any Radio Shack, electronics or possibly hardware store. Select the length that suits your requirements. A 40-foot mast seems to be a good compromise of rigidity and height vs. price.

Final matching will be done at the antenna site, using a relay for dual-band operation (not required for single-band operation), and a capacitor/inductor combination.

On the 160 meter band, the antenna is current-fed by the loading inductor just under the capacity hat. The actual antenna resonance is lower than the frequency of interest, and therefore must be electrically shortened by a series capacitor at the base of the antenna. The capacitor should be preferably an air dielectric, such as a large transmitting variable from 50 to 500 pF. A vacuum variable

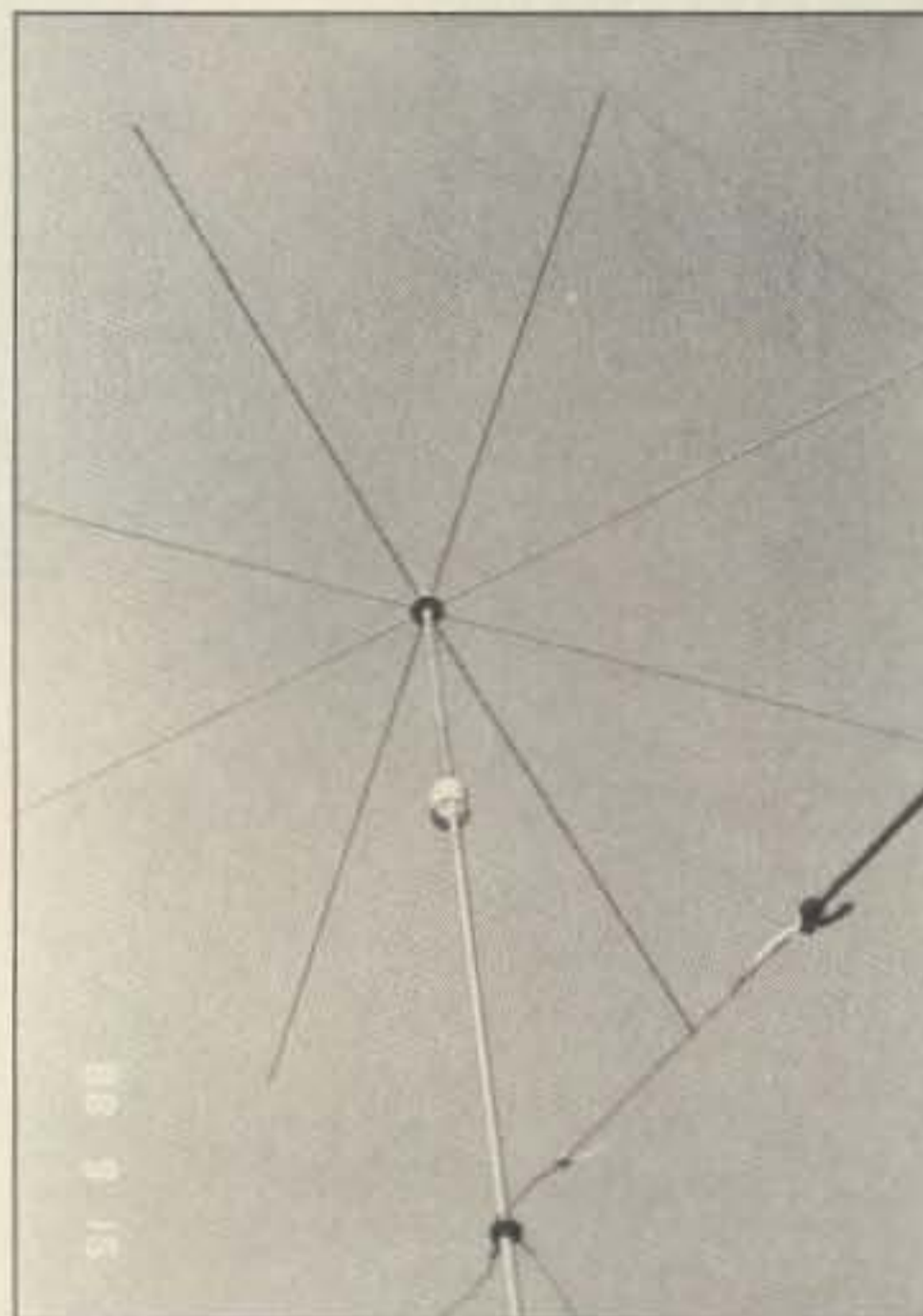

Photo. The dual-band vertical showing the capacity hat and top-loading coil.

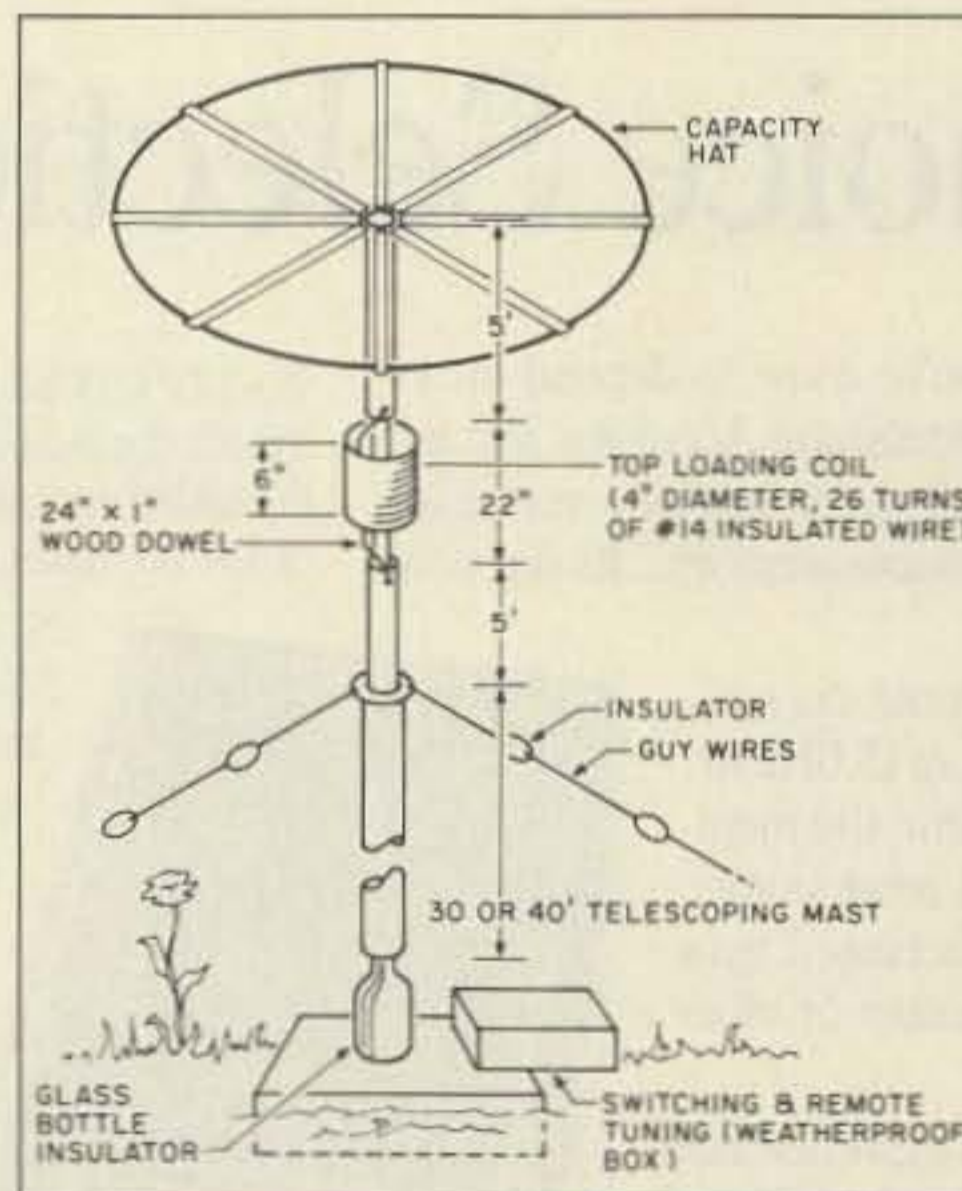

Figure 1. Overall dimensions of the dual-band vertical.

would also be ideal. The larger the tuning range of the variable, the greater the frequency swing across the 160 meter band. The capacitor connects between the antenna and the center of the coax lead, and is tuned for minimum VSWR. With the loading coil near the top of the antenna, most of the current will flow to the top, which is desired.

1750 meter operation is very different, as

this antenna is extremely short at these frequencies. With the size of capacity hat described, a top-loading coil would be very inefficient due to the high amount of inductance required, and the subsequent  $I^2R$  losses from the resistance of the wire. A much larger capacity hat would be required, and would involve consulting your neighbors! Instead we will voltage-feed the antenna using a large prehistoric-size loading coil at the base, and use a tap point on the coil to match it to a low impedance source (transmitter).

By using the capacitive reactance to tune the coil to resonance as a part of the antenna capacitance, the coax actually becomes part of the antenna matching system. This offsets the 50-foot antenna and feedline restriction by turning the coax from a non-reactive transmission line to a reactive component that is part of the tuning circuitry.

The loading coil L1 in Figure 7a can be a regular air-wound inductor, with the number of turns found experimentally. Or you could use a variometer (see the sidebar) that would greatly ease the tuning procedure.

## Construction

Remember before starting that the top loading coil just below the capacity hat can be eliminated if you plan to operate only on 1750 meters.

The capacity hat is made of eight aluminum tubes, each 5-feet long and  $\frac{1}{4}$ -inch thick, purchased at a local hardware store for about a dollar a foot (see Figure 2). At the end of each tube, press a  $\frac{1}{2}$ -inch area flat with pliers, and drill a small hole to accommodate a

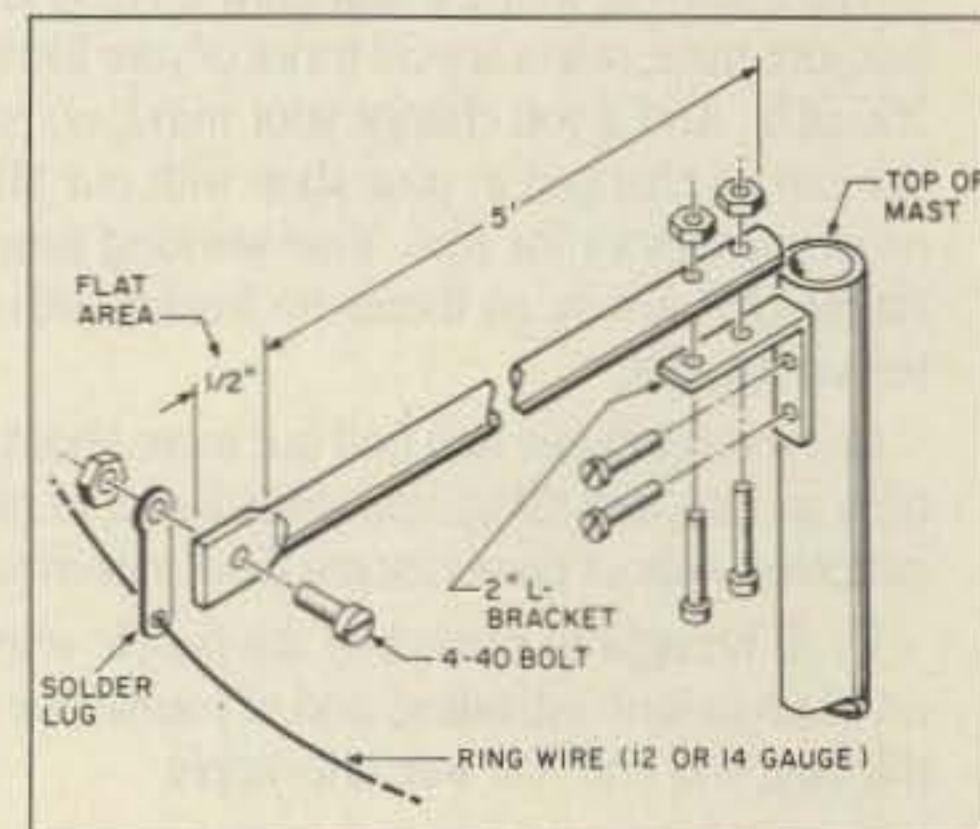

Figure 2. Construction details of the capacity hat tubes. A 2" steel L-bracket is used to attach each tube to the mast. Run a wire ring through the far ends of the tubes to form a large circle (solder the wire ring at the end of each tube).

**HIGH SPEED  
SIGNALLING**

**> DTMF >**

- ANI
- MEMORY DIAL
- STORE & SEND

**STEEL KEYS  
SEALED GOLD CONTACTS**

An ultra high quality DTMF Encoder for absolute reliability and function.

- Software-Driven and Keyboard Programmable
- High Capacity, 30 Digits per Location • Side Tone
- Non-Volatile Memory • Auto Test & PTT Disable
- 5-10-20 DPS, Pure Signalling—No "Pops"
- Speed Adj • Pause Adj • Digit Expand • Wait/Send
- Wide Operating Range: -22 +160°F / 6-26 VDC
- Multi-Function Programming .....

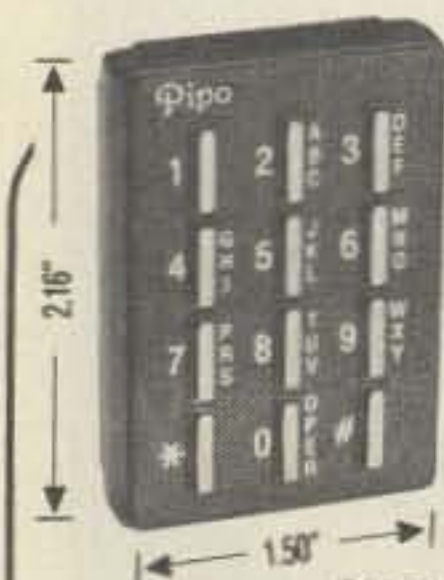

PK-7V, ANI3.2  
PK-7H Horiz. Model

\* Call or write for ANI3.2 Info

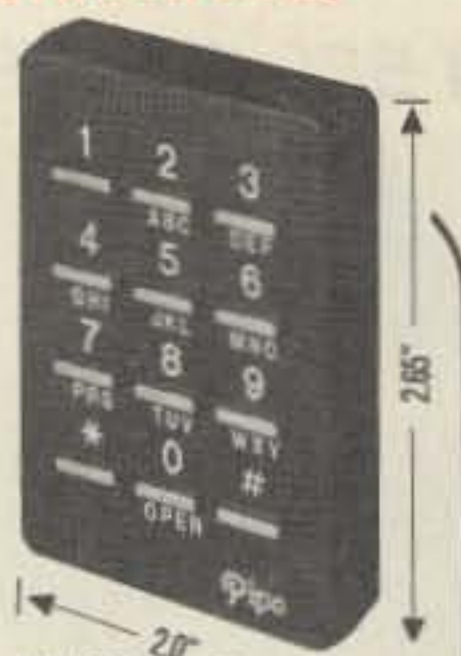

PK-1K, ANI3.2  
W/Relay

Mail  
Order  
To:

**Pipo Communications**  
® *Emphasis is on Quality & Reliability*

P.O. Box 2020  
Pollock Pines, California 95726  
(916) 644-5444  
FAX: 644-PIPO

CIRCLE 66 ON READER SERVICE CARD

**H-T  
POWER  
FOR  
LIFE!**

The Quantum Ham Battery™ may be the last rechargeable battery you'll purchase. Its 12 volt 2.1 amp hour capacity packs up to six times the power of H-T nicad packs.

A simple coiled cord connects Quantum's power to your H-T. If you buy another H-T just get another cord — without the additional cost of new batteries and chargers. The Ham Battery will power all sorts of 12 volt gear — past, present and future.

You'll always know how much power remains. The battery's



status is continuously monitored by a unique L.E.D. display. Its sealed lead cells maintain charge for months and recharge reliably to 100% capacity without the "memory" effect of nicads.

You'll have the power you need when you need it — for emergencies, events, field day, camping, boating, camcorders, cellular phones... even two at once with dual outputs.

Discover what so many other hams have already discovered: the ultimate solution for long lasting H-T power.

**THE QUANTUM HAM BATTERY™**

Call 1-800-989-0505 for ordering (9 to 5 EST)  
Call or write for information or a brochure (516) 222-0611

**MADE IN USA • DEALERS INVITED**

Quantum Instruments Inc., 1075 Stewart Ave., Garden City, NY 11530



4-40 nut and bolt. Use a solder lug so that the ring wire can be soldered securely after the solder lug is tightly fastened with the nut and bolt to the aluminum rod. This makes it easy to install the wire ring. At the other end of each tube, attach a 2-inch steel L-bracket. Drill 8 holes equidistant around the top end of the mast pipe so that the capacity hat tubes can be attached. Mount each tube to the mast as shown in Figure 2.

When you attach the top hat, be sure to twist each rod so that the solder lug at the end will be in a vertical position. The wire chosen as the ring wire should be of large solid variety, and can be insulated. String the wire through each solder lug hole, but not too tight. Clip and solder the end of the wire, and each remaining solder lug, with ample solder. Spray your favorite color of paint on the entire capacity hat assembly for weatherproofing, or paint marine varnish over all sections.

The top loading coil for 160 meters is constructed from 4-inch diameter white PVC pipe, about 5 inches long. 30 turns of #16 gauge stranded wire, Teflon™ insulated, is used for the initial inductor. You could use other coil-form material, such as Plexiglas™. Avoid black-colored PVC tubing!

Wind the coil tightly and paint it with Fiberglass resin. Use solder lugs to secure each end of the coil, and 6-inch wires to connect the coil to the top and bottom mast.

The top section of the mast is five feet of galvanized steel tubing, exactly like the top section of the telescopic vertical. The exact length is not critical since the coil can resonate to almost any reasonable length, but lengths beyond 10 feet can break due to wind resistance. Three to seven feet are recommended. [Ed. Note: If you use a 40 or 50-foot telescoping mast for the antenna, you can cut the top 10-foot section in half to use as the top section.]

When painting the coil, also paint a wooden dowel rod that's about one foot long and fits easily into each vertical section. The idea here is to provide good insulation and solid strength for the top section of the vertical and capacity hat. The wooden dowel works very well for this, and should be inserted into the top of the push-up mast after curing.

**Final Assembly**

Now you may have to make a big decision. Shall it go on the roof or in the yard?? It should be in the clear as much as possible, of course! Absorption from trees and surrounding structures can foul up an antenna of this type. Also, you have to consider a ground system after raising the antenna. Insulated radials (as many as practical) at 50-foot lengths should radiate from the antenna base in equal directions. On roof installations, use either radials, hot and cold water pipes (especially copper ones!), or chicken fence mesh. Many times a combination of these will do an adequate job, especially for the city dweller.

After you've determined the antenna site, make preparations for the insulated base. Many approaches can be used, but the old glass bottle trick works every time, and is

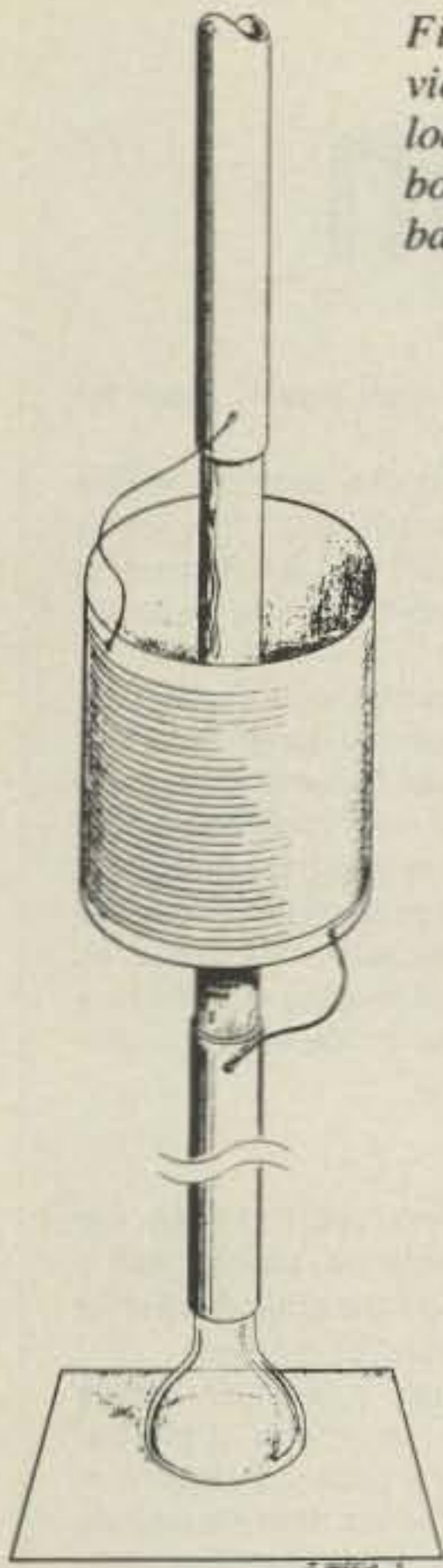

Figure 3. Close-up view of the 160m top loading coil and glass bottle insulator for the base.

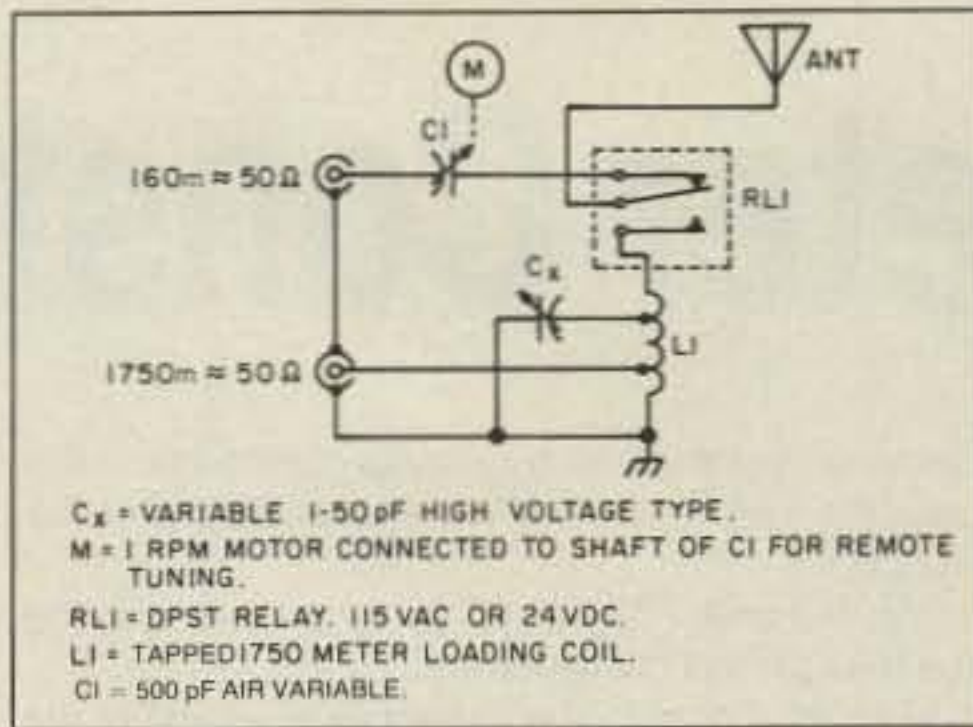

Figure 4. Switching arrangement for dual-band operation.

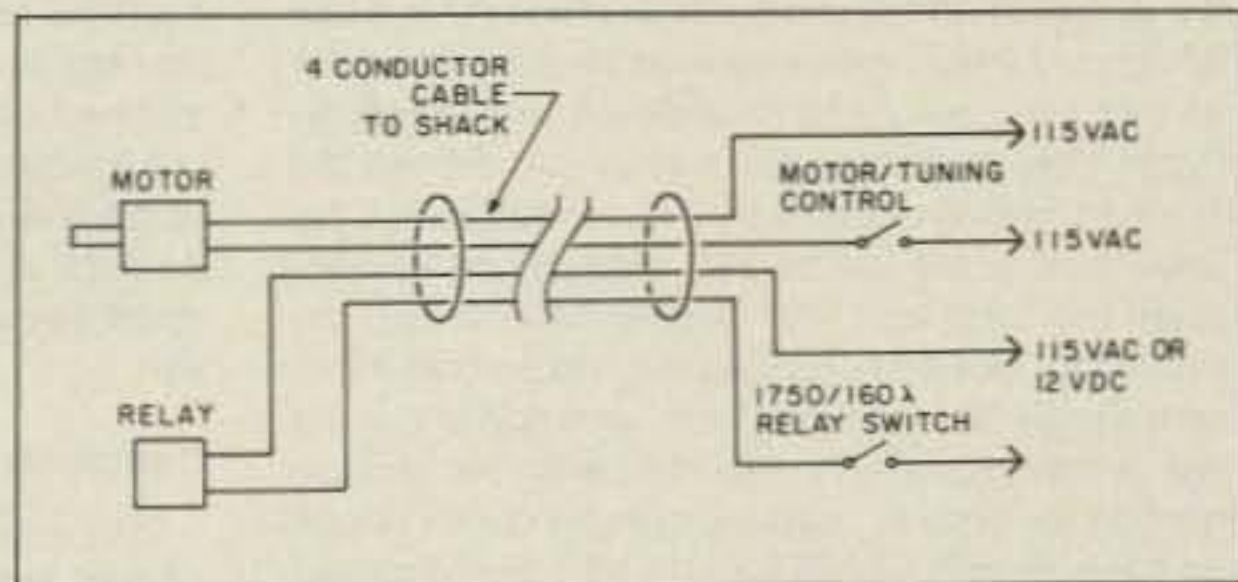

Figure 5. Cable connections for remote tuning.

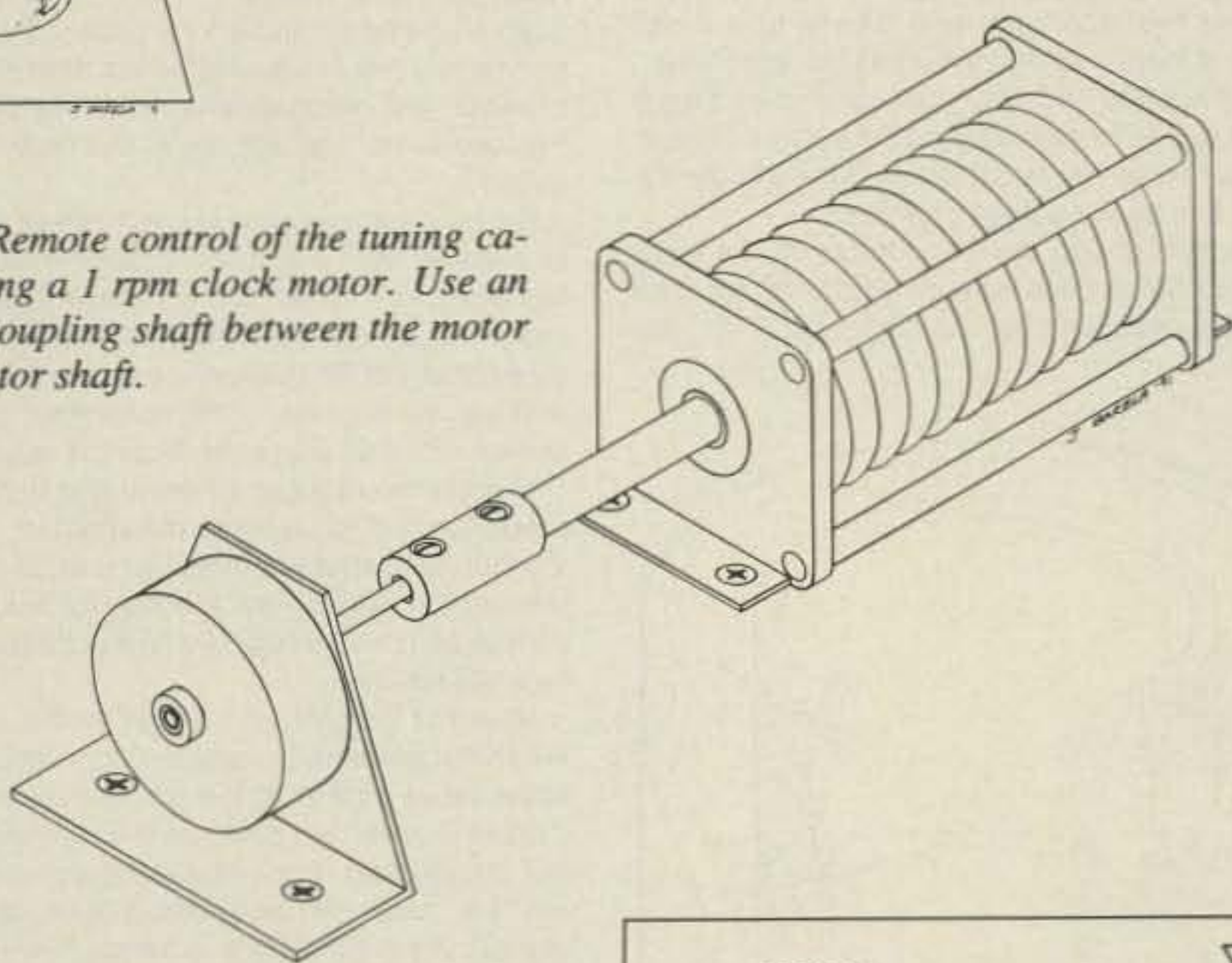

Figure 6. Remote control of the tuning capacitor using a 1 rpm clock motor. Use an insulated coupling shaft between the motor and capacitor shaft.

recommended. The bottle is simply placed in cement that has been prepared and drying. Insert the bottle about four inches into the cement. The cement may be poured into a hole in the ground, for ground installations. A vent pipe can be used for roof mount, but a strong solid insulator, such as a Plexiglas or Teflon rod, must be used as an insulated support. Plastic companies usually carry this product. Alternatively, a cement block can be used with a glass bottle for roof mounts. The guy cables are 1/4-inch polypropylene rope which are adequate but need replacement every couple of years.

The collapsed mast is placed over the insulator and guyed at the 10-foot section. Additional guys are attached, usually at the 30-foot section.

If steel guy wire is used, be sure to use ceramic egg insulators, two per guy to insulate the vertical. Very high voltages exist

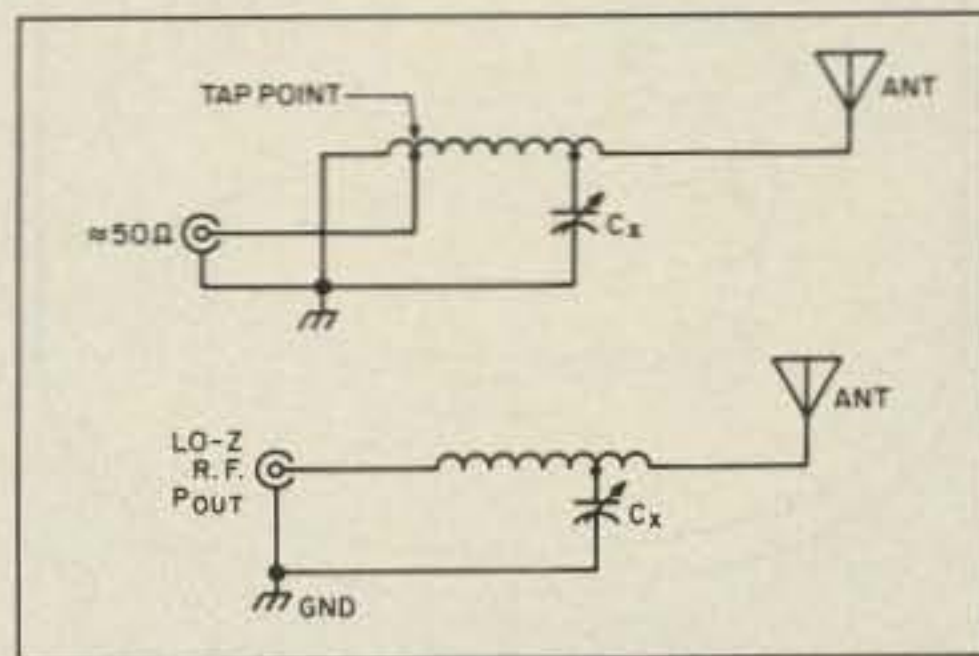

Figure 7. (a) Proper matching to 50 ohm coax. (b) Direct connection to the transmitter at the antenna site.

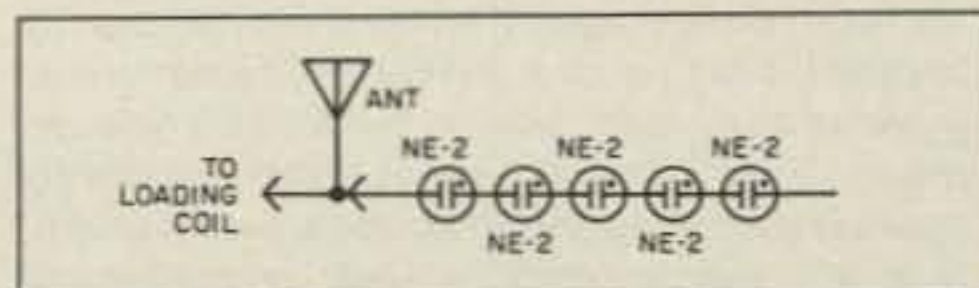

Figure 8. Neon bulbs soldered in series and connected to the antenna. When they reach maximum brilliance, the antenna is resonant.

# COMET

ANTENNAS FOR THE PROFESSIONAL AMATEUR

## MULTI-BAND ANTENNA SYSTEMS

### 146 MHz

### 446 MHz

## DUAL-BAND

**NEW**

◀ CA-2 x 4MAX (Shown)

Base/Repeater Antenna  
 GAIN: 146MHz 8.5dB 5/8 Wave x 5  
 446MHz 11.9dB 5/8 Wave x 12  
 IMPEDANCE: 50 Ohm  
 SWR: Less than 1.5:1  
 144-148 MHz  
 440-450 MHz  
 MAX POWER: 200 watts  
 LENGTH: 17'8"  
 WEIGHT: 5lbs. 12 oz.  
 MOUNTING MAST DIA.: 1 1/4-2 1/2"  
 CONNECTOR: UHF (SO-239)  
 CONSTRUCTION: Heavy Duty Fiberglass SCREW-TOGETHER ABS JOINTS

■ CA-2 x 4Z

Base/Repeater Antenna  
 GAIN: 146MHz 8.2dB 446MHz 11.5dB  
 POWER: 200 watts  
 LENGTH: 15'11"  
 CONNECTOR: N

■ CA-2 x 4FX

Base/Repeater Antenna  
 GAIN: 146MHz 4.5dB 446MHz 7.7dB  
 POWER: 200 watts  
 LENGTH: 5'11"  
 CONNECTOR: UHF type

■ CA-2 x 4MB

Mobile Antenna w/Fold-over feature  
 GAIN: 146MHz 4.5dB 446MHz 7.0dB  
 POWER: 150 watts  
 LENGTH: 5'  
 CONNECTOR: UHF type

■ CA-2 x 4SR

Mobile Antenna w/Fold-over feature  
 GAIN: 146MHz 3.8dB 446MHz 6.2dB  
 POWER: 150 watts FM  
 LENGTH: 3'4"  
 CONNECTOR: UHF type

---

■ CF-416

Duplexer w/Coax  
 POWER: 146MHz 800 watts  
 446MHz 500 watts  
 CONNECTOR OUTPUT: N-type  
 146MHz INPUT: UHF  
 446MHz INPUT: N-type

■ CF-41601 CF-4160K

Duplexer w/o Coax  
 POWER: Same as CF-416  
 CONNECTOR OUTPUT: UHF  
 146MHz INPUT: UHF  
 I MODEL 446 INPUT: N-type  
 K MODEL 446 INPUT: UHF

Call For Your Nearest Dealer Or Catalog  
**1 (800) 962-2611**

**NCG Companies**  
 1275 North Grove Street  
 Anaheim, CA 92806  
 (714) 630-4541/FAX (714) 630-7024

**N.C.G. CO.**  
**NCG**

CIRCLE 54 ON READER SERVICE CARD

# Variometer Construction

A variometer provides an easy way to match low frequency antennas, such as vertical radiators, random length horizontal, or "L" shaped wire antennas, and resonate these at a desired frequency.

A variometer can be thought of simply as two inductors that can slide in and out of each other. Depending on the size of the inductor coil forms, the number of turns, and the size of wire used, the inductance will vary as the magnetic fields of both coils either aid or cancel each other as the two coils are moved within each other's proximity.

One of the coils can be made small enough to rotate inside the larger coil, and the magnetic flux can be added or subtracted by rotating the inside coil. To do this, both coils must be connected in series. The variometer is wired so that the smaller rotating inductor is connected within the large outer one. Optimum efficiency will occur when both coils aid or add to each other for maximum inductance.

During initial calibration, after rotating the inside inductor to resonance, it may be beneficial to remove wire from the variometer. This is especially desirable from the standpoint of higher efficiency and better *Q*.

The whole point of the variometer is to find the ballpark resonance of your antenna system, then optimize the variometer by removing or adding turns, if required.

## Assembly

First, wind the large coil form.

Usually, a range of 5–8 mH for a 30–50 foot vertical antenna will be within the 1750 meter limits. A vertical antenna such as this should also have at least a 5-foot capacity hat for improved radiation resistance. Wire gauges from 18 to 26 work well, with the small gauge wire providing more turns per inch and more inductance. Number 22 gauge wire does a fine job overall, and you'll need at least 200 feet.

Two small holes, one at each end of the coil form, is used for terminating each end of wire after winding.

Tape one end of wire with masking or Scotch™ tape to, or near, a hole at the end of the coil form. Sit in a chair or couch with the form in your lap. The spool of wire should be on the floor, leading up to the form.

Turn the form with one hand and use the other hand to guide the wire taut against the form. A tight, even layer is required. After 20 or 30 turns you might want to stop and push the turns closer, if required.

Masking tape will hold the turns in place when you stop. In the middle of the form are two 1/4-inch holes directly opposite each other, with a small hole next to each one. Wind the turns carefully around these holes so that you don't block them, because the holes will be used later on in assembly.

A 4-40 screw with a solder lug can be installed at the end hole to terminate the wire. The insulation should be removed with fine sandpaper or a stripping chemical, and then inserted through the eye of the solder lug and twisted. Make sure that there isn't any slack that could loosen the turns of the wire. Repeat this procedure for the other end of the coil using a 4-40 screw and nut, and a solder lug terminal. If desired, a spray varnish can be used to add weatherproofing and protection. Use only a clear varnish or enamel.

Now wind the smaller coil form in a similar fashion. Because this form is so small by comparison, it may not be necessary to take the same precau-

tions as before. The only major difference is the way the wire is installed in the form itself. (See the figure.)

At this time, varnish or spray enamel may be used to protect the inside coil.

The final step in the assembly is to install the small coil inside the larger one, and wire the two inductors together. Locate the nylon threaded rod and nylon nuts. Push the rod through one end of the large coil and screw a nut on. Turn the rod and advance the nut, then screw on another nut. After an inch or so, place the smaller coil form inside the larger one, and place the end of the rod into the 1/4-inch hole in the center of the small form. Continue to turn the rod so that it advances into the small coil form and add another two nuts on the nylon rod. Continue turning the rod so that it can go through the small coil form, and add one more nut. A total of six nuts are used, with four of them holding the smaller coil directly in the center. Tighten the nuts with FINGERS ONLY! The rod should extend completely through the large coil, with one end longer to provide a knob to turn it with. At this end, add the last nut on the outside of the large coil, and screw it so it is tight with the inside screw, centering the small coil and providing a small amount of friction so that the small coil won't slip.

Take the wires from the small coil and lead each wire through the small holes on the larger coil form.

These two wires should follow closely to the nylon rod, and have no kinks or twists.

Once fed through the small holes on the large form, clip the excess wire so that only 1/4 inch remains extending from the large coil form. Re-



The diagram shows that the wire is first fed backwards out of the hole (A), and down the inside toward the center (B), and then outside with approximately 3–4 inches remaining. This remaining end will go through the small hole at the center of the large coil form later. With the wire at (A) and (B) installed, wind the form completely, being sure to leave an open space around the 1/4-inch holes at the end. Push tightly all turns so that the most wire possible can fit on the form. Before cutting any wire, add approximately two feet, after inserting the wire through the hole (C). Now, cut the wire and feed it through hole (C), down inside toward the center and through hole (D), to the outside.

move the enamel so that each wire is clean for soldering.

At this point, cut the wire on the large coil, where it goes between the two 1/4-inch holes. This will be right in the middle of the coil, and will be easy to locate since it is a single wire in between the upper and lower sections.

If no varnish has been applied to the larger coil, you will need to add tape over the upper and lower sections so the turns will not become loose after you cut the wire. Each of the cut wires should be trimmed back and soldered to one of the wires from the inside coil. Snip the wires from the larger coil and solder, one on each side, to the 1/4-inch wires on each side from the small rotating coil. Allow a small amount of slack on the inside wires for rotation.

## Operation

The variometer is connected between the ground systems and the antenna, usually with a tap point several turns up from the ground side that connects to the transmitter and/or receiver.

For systems involving only a receiver, simply rotate the small coil of the variometer at the frequency of interest and note a peak in reception. If there is no peak in signal strength, then it is entirely possible that resonance is occurring elsewhere. Remove turns from the top of the outer coil if required.

For transmitting purposes, remove as much wire as possible from the outer coil after the frequency has been determined and experimentation has located the variometer's point of resonance. Measure either the RF voltage across the 50 ohm load with an oscilloscope or RF voltmeter, or the RF current to the 50 ohm load. Note the value.

Monitor the radiated RF level and turn the variometer control to resonate the antenna. A receive monitor, field strength meter, or a small neon bulb placed near the antenna is useful for this. Antenna voltage can be very high. Avoid touching the antenna while tuning.

Note the current or voltage at the tap point. When the antenna is resonant, this should be the same value as that of the 50 ohm resistor. If the current is lower, go down on the tap point toward the ground end. For voltage measurements that are low, raise the tap point higher, away from ground. Re-resonate the antenna every time you change the tap point.

An optimum point will be reached where the tap point will have the same voltage and/or current, as was noted with the 50 ohm resistor, when the antenna is a resonance. Using a nonreactive 50 ohm load as a reference makes it very easy to adjust transmitters and antennas on 1750 meters.

Sophisticated equipment, such as an oscilloscope, is handy, but a small Ne-2 bulb will suffice in a pinch. Several Ne-2 bulbs soldered together in series will also work as a reference for monitoring voltage across the antenna. This is only for reference and does not indicate antenna efficiency.

Sometimes there may be difficulty in rotating the inner coil due to rubbing between the two. Adjusting the four screws that secure the inner coil will either expand or contract the coil center. Wire turns around the coil form sometimes warps the form slightly. Placing pressure will compensate for this. After this is done, set the two nuts on the outer coil form to gently hold the inner coil in the center.

A complete variometer kit is available (not including wire) for \$68.95 postpaid from: Curry Communications, 852 North Lima Street, Burbank CA 91505.



DAN KB0XC—KIRBY KA0ZTS—LOUIS KA0IPN  
RON N0KMR—DENISE YL—MALINE XYL—MIKE S00N

1-800-426-2891

**YAESU**



	LIST	Call \$
FT-767 GX Gen. Cvg Xcv	2299.00	Call \$
FT-757 GX II Gen. Cvg Xcv	1299.00	Call \$
FT-7000 15m-160m AMP	999.00	Call \$
FT-212RH NEV 45w	999.00	Call \$
FT-712RH 70cm		Call \$
FT-290R All Mode		Call \$
FT-23 R/T		Call \$
FT-736R, All		Call \$
FT-470 2m/70cm		Call \$
FT-747 Gen'l		Call \$
FRG 8800 H		Call \$
FRG 9600 UHF Rcv		Call \$
FT 690 R/H		Call \$
FT 790 R/H		Call \$
FT 4700 Dual Band M		Call \$
FT 411 2 Meter HT	406.00	Call \$
FT 811 440 HT	410.00	Call \$

**FT-26R  
Now  
In  
Stock**

**ICOM**



	LIST	Call \$
IC-781 New Deluxe HF Rig	6149.00	Call \$
IC-765 Gen. Cvg Xcvr	3149.95	Call \$
IC-735 Gen. Cvg Xcvr	1149.00	Call \$
IC-751A Gen. Cvg Xcvr	1149.00	Call \$
IC-R7000 2m/70cm HT	1149.00	Call \$
IC-R71A		Call \$
IC-228A/H		Call \$
IC-28A/H		Call \$
IC-2		Call \$
IC-900 Six		Call \$
IC-3S AT		Call \$
IC-2S AT		Call \$
IC-4S AT		Call \$
IC-48A FM Mobile 25w	99.00	Call \$
IC-4GAT New 6w HT	9.95	Call \$
IC-38A 25w FM Xcv	489.00	Call \$
IC-32AT 2m/70cm HT	629.95	Call \$

**IC-725  
Get Ready  
For HF!**



R. F. Concepts  
Astron  
Butternut  
ARRL  
Kantronics  
Sony  
Bencher  
KLM/Mirage

Larsen  
Hustler  
Lakeview  
AEA  
MFJ  
Cushcraft  
Vibroplex

Plus more . . . Thanks for your support.

1-800-426-2891

METRO: (612) 786-4475

2663 County Rd. 1

Mounds View, MN 55112

Super Minnesota Watts 1-800-279-1503

CIRCLE 153 ON READER SERVICE CARD

when you use the antenna on 1750 meters, and high voltages exist on the capacity hat on both 160 and 1750 meters. You'll need a ladder next to the vertical, and rigid gloves to raise each section. Insert the wooden dowel with the top-loading coil placed about two inches above the mast.

With two small screws, bolt the coil to the side of the dowel. Clean the top of the mast in a small area. The wire from the bottom of the coil is soldered at this point. Place the top vertical and capacity hat section on the dowel rod, and clean it for soldering to the top of the loading coil. Raise the top section of the mast and tighten the section after being extended. Raise the next section and secure this after being fully extended. After all sections have been raised, check the guys and adjust the antenna into a vertical position.

You can add strength to the vertical joints by drilling 1/4-inch holes through each joint and securing them with a nut and bolt through the smaller hole where the cotter pin is usually located. These masts can be quite flimsy when you're raising them. Be extra careful around power lines.

#### Loading Coil and Matching

Figure 4 shows remote switching and tuning of the antenna. A 1 rpm motor (M) is connected to capacitor C1 (Figure 6). Relay RL1, a power relay, will withstand at least 220 volts. This is required since high voltages exist with this type of antenna on 1750 meters. Using these will provide easy control right in the comfort of your own shack!

#### 160 Meter Calibration

Connect an SWR meter between the transmitter and antenna. Place the transmitter into the transmit position, using low power in a clear portion of the 160 meter band that will be the frequency of interest.

Rotate the capacitor and notice the SWR meter for a dip. If no dip is indicated, try a lower or higher frequency. The top loading coil may need turns removed or added to facilitate tuning and lowest SWR. Capacitance of C1 lower than 50 pF should be avoided.

Poor ground systems will also deteriorate the lowest possible SWR. Shorting C1 will cause the antenna to resonate at its natural resonant frequency, which should be around 1750 kHz. The capacitor shortens the wavelength of the antenna into the 160 meter band, but a point of no-return can happen if the natural resonant frequency of the antenna is much lower than 1750 kHz.

#### 1750 Meter Band Operation

Three to seven mH will be required to resonate this antenna on 1750 meters. A variometer (see the sidebar) is a convenient way to find resonance and match the antenna. Figure 7a shows proper matching to a coax, and Figure 7b can be used for direct connection to a transmitter at the antenna site. The coil in Figures 7a and b is tapped approximately five turns from the ground end, and can be found by simulating the tap point with a 50 ohm load.

#### Tune-Up

Transmit a signal on the desired frequency into a 50 ohm load and note either the current or voltage across to load. Replace the load with the tap point at the antenna site, and resonate the antenna by varying the inductance of the coil. Capacitor Cx is a 25 pF (value not critical) high voltage variable that is temporarily inserted to aid in finding the ballpark frequency resonance of the antenna, in case it's off-frequency. Cx should be removed or minimized for best efficiency. Adjust Cx and then add or remove turns on L1 until Cx becomes a very small value or not required at all.

Monitor the signal strength with a remote receiver or field strength meter. Figure 8 shows several neon bulbs soldered in series that are connected to the antenna. As the antenna approaches resonance, the bulbs begin to shine brighter. Once our aim, maximum brilliance, has been reached, note the current or voltage at the tap point. If there is a difference between this value and the value noted across the 50 ohm resistor, change the tap point and re-resonate the antenna. Do this procedure several times until the antenna is resonant and the SAME value is indicated at the tap point as with the value noted with the 50 ohm resistor.

This is the relative 50 ohm tap point on the loading coil, when the antenna is resonant at that specific frequency. The reactive element of the coax is absorbed by resonating the coil and antenna, providing a part of the total matching system. The direct coil method in Figure 7b can be used for beacon transmitters (for example), with the loading coil ground end connected instead to the transmitter output.

The loading coil can be made by using a large coil form, about six inches in diameter and 10 inches long, wound tightly with #18 gauge enameled wire. Plexiglas or white PVC tubing is excellent for this application. You'll have to experiment to find the exact amount of inductance required for antenna resonance. It is easy to accidentally resonate the antenna on the second harmonic. Check the signal with a receiver on both fundamental and harmonic frequencies to confirm power output on the fundamental frequency.

A car battery box (or any weatherproof enclosure) can be used to house the capacitor, relay and 1 rpm motor. The coil should be located in the clear with a coat of marine varnish after installation is complete.

Check out information on mobile 160 meter antennas for an understanding of how 1750 short verticals operate. They are very similar in principle. These short vertical antennas offer reliable results, and they're a good compromise of size vs. performance. **73**

You may reach David F. Curry WD4PLI at 852 N. Lima Street, Burbank CA 91505. The owner of Curry Communications, David offers a variometer kit for this project for \$68.95, postage paid.